

SLI250 INDUSTRY HLE

Technical specifications

Lifting cap. arm in/out	250/50kg - 550/110lb
Lifting height	4,10m / 13,45ft
Extension of arm	900+900mm / 2,95+2,95ft
Tilt	56° back / 62° fwd
Side shift	100mm / 4in
Charging voltage	230 V / 110V
Charging time	Approx. 8 hrs
Running period	Up to 10 hrs
Rear-wheel drive	700W
Width	0,68m / 2,23ft
Curb weight	550kg / 1210lb

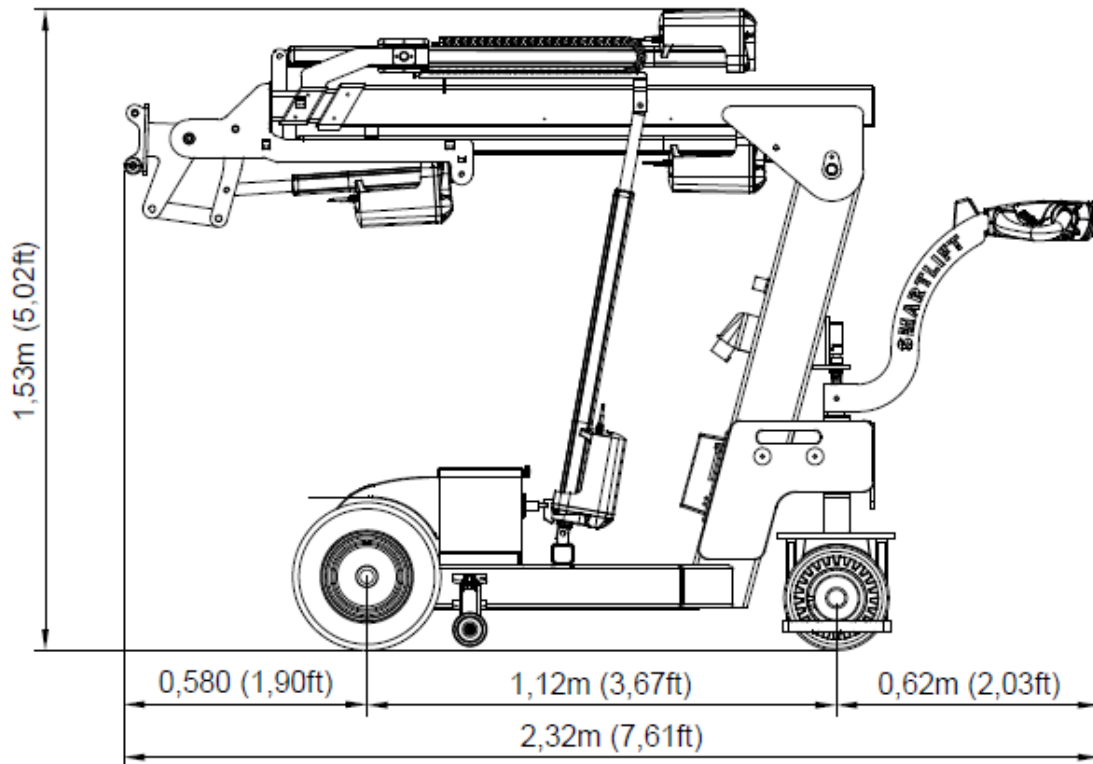
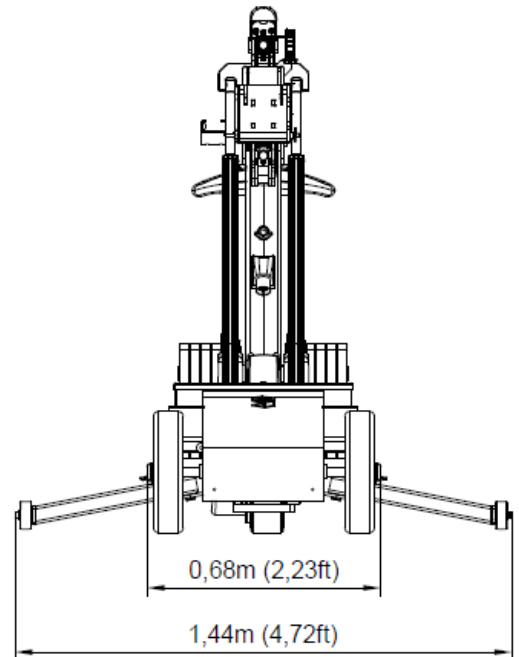

Load chart

